

# VTLF 200–500 Series

ISO 9001 Certified  
CE Compliant

## 100% OIL-LESS VACUUM PUMPS

The Becker VTLF 200–500 series pumps are 100% oil-less rotary vane vacuum pumps. They are designed to operate on a continuous basis at any point from atmospheric pressure to a maximum vacuum level of 25" HgV, depending on the model.

The VTLF series pumps are direct drive units and are supplied with TEFC flange mounted electric motors. Each pump is equipped with an integral vacuum relief valve, a 4 micron inlet filter, exhaust silencer, and vibration isolators as standard equipment.

These 100% oil-less, or dry, pumps are ideal for applications where oil or water use is objectionable. All Becker VTLF series pumps use long-life, self-

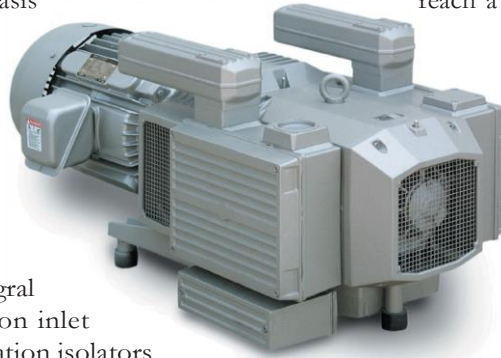

lubricating graphite composite vanes. Applications include those where regenerative blowers cannot reach a deep enough vacuum, or those where oil-flooded vacuum pumps operate at vacuum levels that emit excessive oil aerosols, often referred to as "smoke". VTLF pumps are ideal for graphic arts, packaging, vacuum chucking, robotics and material handling, medical/surgical, and air sampling, among others.

Also available in tank mounted simplex and duplex, and modular/expandable central vacuum system configurations. Pressure and combination pressure/vacuum pumps are also available

### ABSOLUTE PRESSURE (TORR)

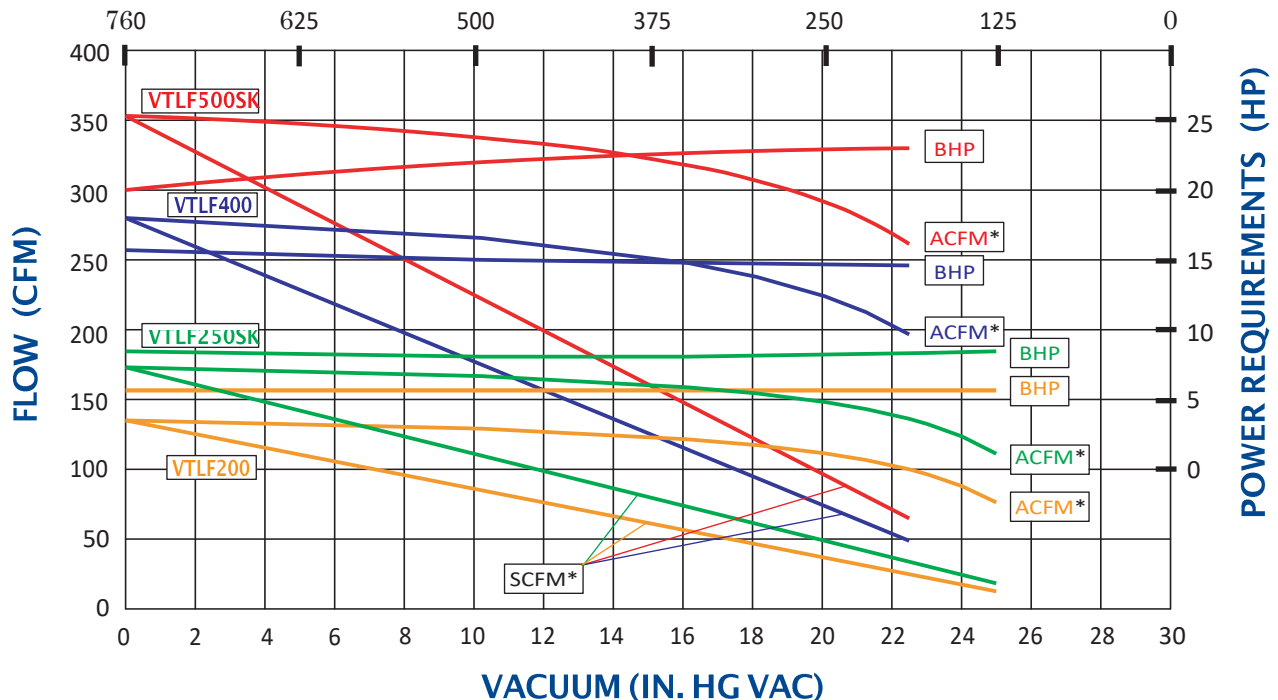

#### САНКТ-ПЕТЕРБУРГ

188508, тер. Южная часть производственной зоны Горелово, ул. Понсе, д. 18  
8(800)775-49-61  
www.megatechnika.ru

#### МОСКВА

111395, ул. Юности, д.5, стр.4  
8(800)100-78-28  
www.megatechnika.com

#### УФА

450001, ул. Комсомольская, д. 2  
8(347)246-63-16  
ufa@megatechnika.ru

#### СЕРВИС

8-800-100-77-83  
Звонок по России бесплатный

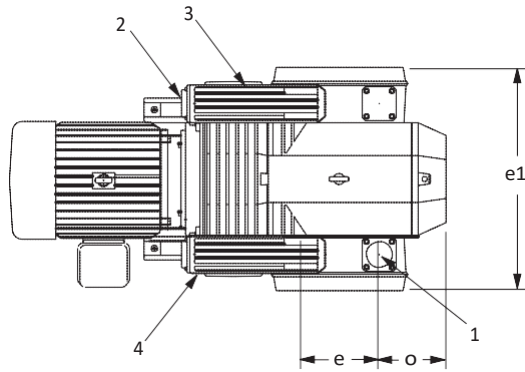

**Top View**

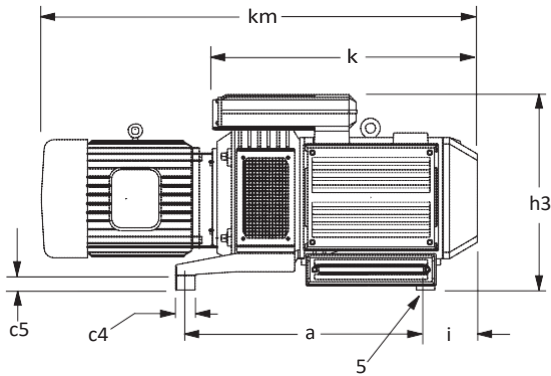

**Side View**

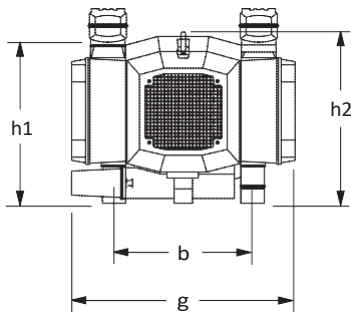

**End View (Opposite Motor End)**

All data based on 60 Hz operation

	VTLF200	VTLF250SK	VTLF400	VTLF500SK
Flow (SCFM @ 0 in. Hg)	130	173	280	353
Horsepower (kW)	7.5(5.6)	10(7.5)	18(13.2)	24(18)
Speed (RPM)	850	1150	850	1150
Max. Cont. Vacuum (in. Hg)	25	25	22.5	22.5
Weight (lbs.)—w/ motor*	865	865	1090	1100
Noise Level (Max. dBA)	77	81	78	83
Inlet size (BSP, inches)	2"	2"	4"	4"
<b>Dimensional Data</b>	(Inches)			
a	25.4	25.4	30.25	30.25
b	15.0	15.0	18.9	18.9
c4	2.0	2.0	3.0	3.0
c5	1.6	1.6	2.0	2.0
e	8.5	8.5	10.6	10.6
e1	16.66	16.66	20.87	20.87
g	24.1	24.1	30.17	30.17
h <sub>1</sub>	16.87	16.87	20.86	20.86
h <sub>2</sub>	18.35	18.35	22.72	22.72
h <sub>3</sub>	21.0	21.0	27.96	27.96
i	4.92	4.92	6.5	6.5
k	28.25	28.25	33.0	33.0
km*	51.75	51.75	48.4	57.1
o	6.75	6.75	8.12	8.12

\* Overall specifications for units may vary due to motor provider. Contact factory for information.  
 Manufacturer reserves right to alter data without notice.

- 1 - Inlet Port
- 2 - Discharge Port
- 3 - Discharge Silencer
- 4 - Vacuum Relief Valve / Silencer
- 5 - Vibration Isolators

**САНКТ-ПЕТЕРБУРГ**

188508, тер. Южная часть производственной зоны Горелово, ул. Понссе, д. 18  
 8(800)775-49-61  
 www.megatechnika.ru

**МОСКВА**

111395, ул. Юности, д.5, стр.4  
 8(800)100-78-28  
 www.megatechnika.com

**УФА**

450001, ул. Комсомольская, д. 2  
 8(347)246-63-16  
 ufa@megatechnika.ru

**СЕРВИС**

8-800-100-77-83  
 Звонок по России бесплатный