

U4.70—U4.250 Series

OIL-FLOODED VACUUM PUMPS

The Becker U4.70-U4.250 series comprises 5 models, each available in two versions: the SA series for general industrial vacuum applications, and the F series, for applications where higher vacuum levels are needed. They are highly efficient oil-flooded rotary vane designs that incorporate an oil reservoir, multi-stage oil separation system, radiator-style oil-cooler, anti-suckback valve, vibration isolators, and high-efficiency direct-drive motor as standard equipment.

Each pump is designed to operate on a continuous basis, and can be operated with its inlet blanked off. The SA series models have an ultimate pressure of 2 torr, and are intended for use at vacuum levels above approximately 20 in. HgV (below 250 torr), but can be operated at any vacuum level, depending on conditions.

The F series pumps are best for use when the absolute operating pressure is above 28 in. HgV (below 50 torr). They have an ultimate pressure of 29.9 in. Hg. (0.4 torr).

The U4 series pump is a direct drive unit and is supplied with a High Efficiency TEFC flange mounted electric motor. Becker U4 series pumps are supplied from the factory

with an initial charge of Becker semi-synthetic oil to ensure the best possible beginning for your pump. What's more, if you use our oil throughout the full warranty period, and follow recommended oil change intervals, we will *double* the standard warranty to a full two years!

**Initial supply
of Becker
semi-synthetic
oil included
with purchase.**

Options include gas ballast (as shown in photo below, left), oil level switches, internal heaters, and water cooled oil coolers.

Becker U 4 series pumps are ideal for applications where high volumetric efficiency is needed throughout the operating range.

Applications include packaging, vacuum chucking, medical/surgical, thermoforming, food processing and packaging, degassing/deaerating, lasers, and molding.

Tank mounted and modular/expandable central vacuum systems are available with capacities up to 2640 CFM.



U4.70SA

Central Vacuum Systems with
up to 6 Pumps are Available!

САНКТ-ПЕТЕРБУРГ

188508, тер. Южная часть производственной
зоны Горелово, ул. Понссе, д. 18
8(800)775-49-61
www.megatechnika.ru

МОСКВА

111395, ул. Юности, д.5, стр.4
8(800)100-78-28
www.megatechnika.com

УФА

450001, ул. Комсомольская, д. 2
8(347)246-63-16
ufa@megatechnika.ru

СЕРВИС

8-800-100-77-83
Звонок по России
бесплатный

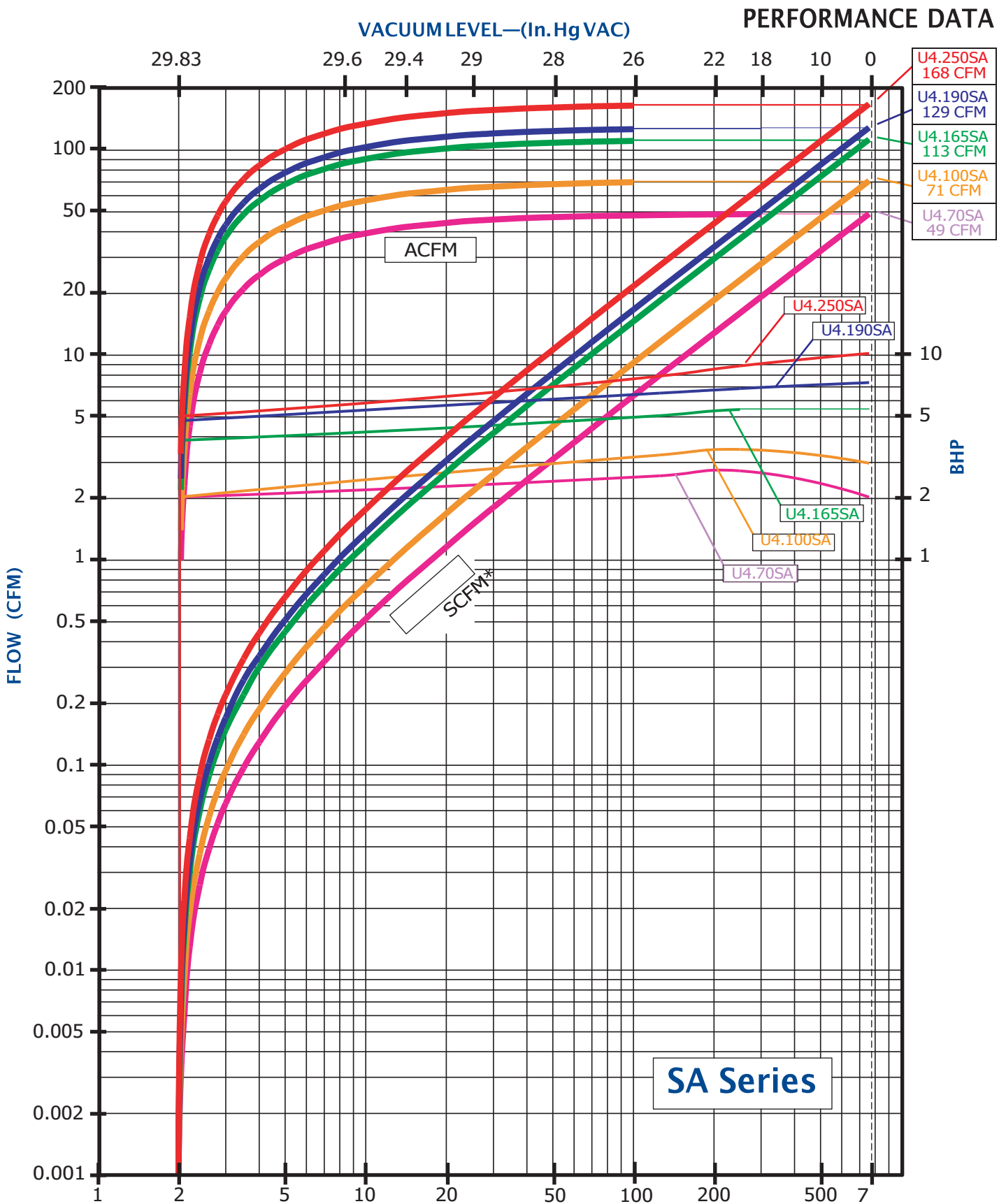

САНКТ-ПЕТЕРБУРГ

188508, тер. Южная часть производственной зоны Горелово, ул. Понссе, д. 18
8(800)775-49-61
www.megatechnika.ru

МОСКВА

111395, ул. Юности, д.5, стр.4
8(800)100-78-28
www.megatechnika.com

УФА

450001, ул. Комсомольская, д. 2
8(347)246-63-16
ufa@megatechnika.ru

СЕРВИС

8-800-100-77-83
Звонок по России бесплатный

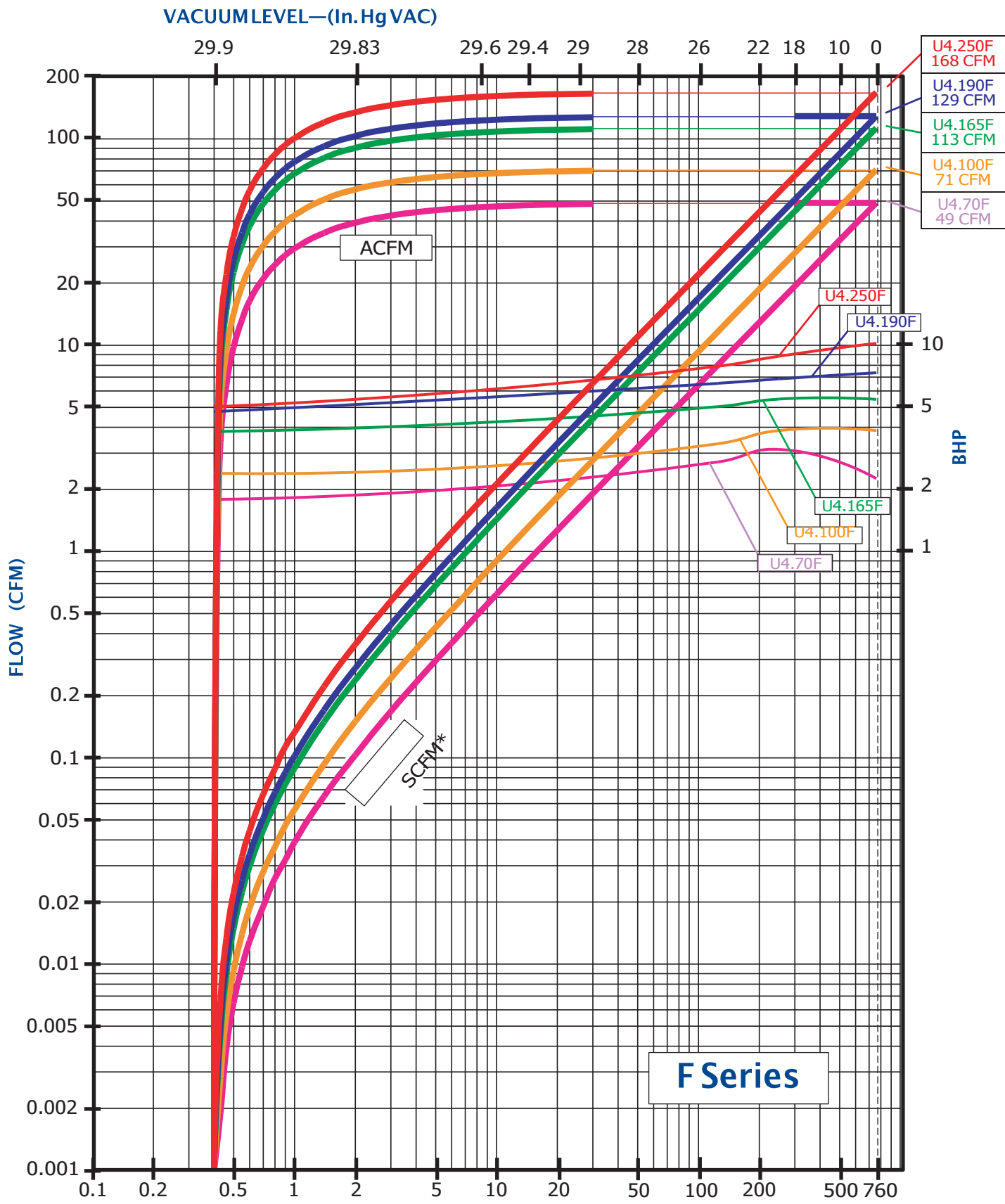

САНКТ-ПЕТЕРБУРГ

188508, тер. Южная часть производственной
зоны Горелово, ул. Понссе, д. 18
8(800)775-49-61
www.megatechnika.ru

МОСКВА

111395, ул. Юности, д.5, стр.4
8(800)100-78-28
www.megatechnika.com

УФА

450001, ул. Комсомольская, д. 2
8(347)246-63-16
ufa@megatechnika.ru

СЕРВИС

8-800-100-77-83
Звонок по России
бесплатный

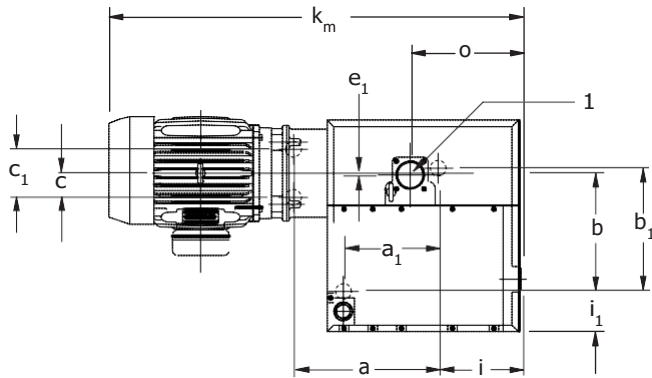

Top View

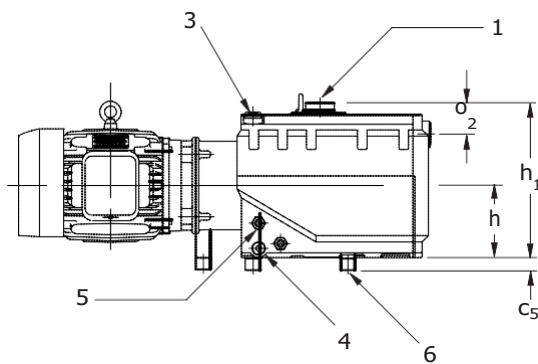

Side View

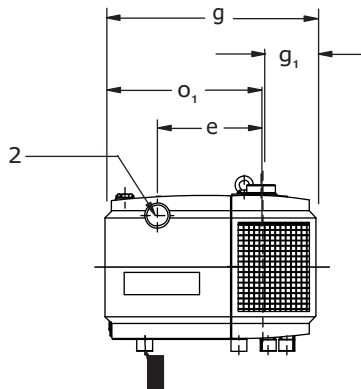

End View (Opposite Motor End)

TECHNICAL DATA

All data based on 60 Hz operation

	U 4.70	U 4.100	U 4.165	U 4.190	U 4.250
Flow (SCFM @ 0 in. Hg)	49	71	113	129	168
Horsepower	3	5	5	7 1/2	10
Speed (RPM)	1740	1740	1740	1740	1740
Ultimate Pressure, SA (torr)‡	2	2	2	2	2
Ultimate Pressure, F (torr)‡	0.4	0.4	0.4	0.4	0.4
Weight (lbs.)—w/ motor*	119	170	302	371	415
Noise Level (Max. dBA)	68.5	69	74	76	76
Inlet size (BSP, inches)	1 1/4	1 1/4	2	2	2
Discharge size (BSP, inches)	1 1/4	1 1/4	1 1/2	1 1/2	1 1/2
Dimensional Data					
	(Inches)				
a	9.29	11.46	11.91	14.27	16.62
a ₁	5.02	5.02	9.35	9.35	9.35
b	7.95	7.95	11.67	11.67	11.62
b ₁	8.39	8.39	12.16	12.16	12.16
c	0.2	0.2	—	—	2.36
c ₁	—	—	2.36	2.36	4.72
c ₅	0.79	0.79	1.18	1.18	1.18
e (Q ₁ inlet to discharge)	5.37	5.37	10.3	10.3	10.24
e ₁ (Q ₁ inlet to motor)	1.25	1.25	0.18	0.18	0.13
g	14.72	14.72	20.91	20.91	20.91
g ₁	4.73	4.73	5.26	5.26	5.36
h	5.32	5.32	7.09	7.09	7.09
h ₁	11.02	11.02	15.16	15.16	15.16
i	6.95	6.95	8.19	8.19	8.19
i ₁	2.05	2.05	3.97	3.97	3.97
k _M	27.1	31.47	35.0	39.19	42.46
o	8.55	8.55	10.95	10.95	10.95
o ₁	8.76	8.76	15.48	15.48	15.48
o ₂	1.18	1.18	1.93	1.93	1.93

** May vary with motor type and manufacturer

‡ With Gas Ballast closed

- 1 - Inlet Port
- 2 - Discharge Port
- 3 - Oil Fill Port
- 4 - Oil Drain Plug
- 5 - Oil Level Sight Glass
- 6 - Vibration Isolator

САНКТ-ПЕТЕРБУРГ

188508, тер. Южная часть производственной зоны Горелово, ул. Понссе, д. 18
8(800)775-49-61
www.megatechnika.ru

МОСКВА

111395, ул. Юности, д.5, стр.4
8(800)100-78-28
www.megatechnika.com

УФА

450001, ул. Комсомольская, д. 2
8(347)246-63-16
ufa@megatechnika.ru

СЕРВИС

8-800-100-77-83
Звонок по России
бесплатный