

DIMENSIONI D'INGOMBRO
Overall dimensions
POMPE CENTRIFUGHE MONOSTADIO
Monostage centrifugal pumps
SERIE
Series **TCT gr. 1-2** pag.2/2

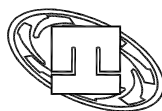

pompetravaini S.p.A.
CASTANO PRIMO (MILANO)

Versione **MONOBLOCCO / M** **CLOSE - COUPLED / M** construction

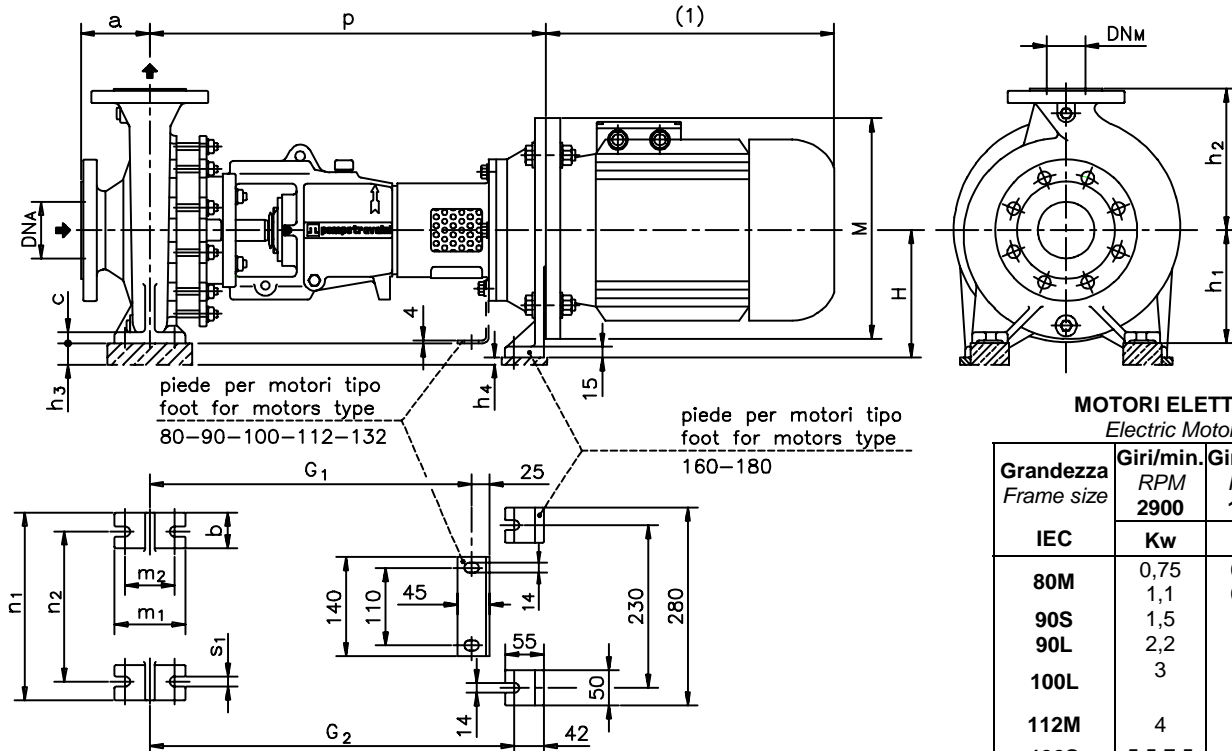

MOTORI ELETTRICI
Electric Motors

Grandezza Frame size	Giri/min. RPM		M
	2900	1450	
IEC	Kw		
80M	0,75	0,55	200
	1,1	0,75	
90S	1,5	1,1	200
	2,2	1,5	
90L	3	2,2	250
		3	
100L			250
112M	4	4	250
132S	5,5-7,5	5,5	300
		7,5	
132M			300
160M	11-15	11	350
	18,5	15	
160L			350
180M	22	18,5	350
180L		22	350

Pompa tipo Pump type	Versione MONOBLOCCO CLOSE-COUPLED construction																
	motore motor 80-90		motore motor 100-112		motore motor 132		motore motor 160-180										
	p	G ₁	Peso Weight	p	G ₁	h ₃	Peso Weight	p	G ₁	h ₃	Peso Weight	H	h ₃	h ₄	p	G ₂	Peso Weight
32-125	466	430	42	491	430	20	46	496	430	48	49	180	68	-	536	497	55
32-160	472	436	48	497	436	-	52	502	436	28	55	180	48	-	542	503	61
32-200	472	436	52	497	436	-	56	502	436	-	59	180	20	-	542	503	65
40-125	466	430	44	491	430	20	48	496	430	48	51	180	68	-	536	497	57
40-160	472	436	48	497	436	-	52	502	436	28	55	180	48	-	542	503	61
40-200	472	436	54	497	436	-	58	502	436	-	61	180	20	-	542	503	67
40-250				613	573	-	92	634	595	-	98	200	20	-	663	618	108
50-125	466	430	48	491	430	-	52	496	430	28	55	180	48	-	536	497	61
50-160	472	436	53	497	436	-	57	502	436	-	60	180	20	-	542	503	66
50-200	472	436	55	497	436	-	59	502	436	-	62	180	20	-	542	503	68
50-250				613	573	-	100	634	595	-	103	200	20	-	663	618	113
65-160				606	566	-	85	627	588	-	88	200	40	-	656	611	98
65-200				606	566	-	92	627	588	-	95	200	20	-	656	611	105
65-250				619	579	-	100	640	601	-	103	200	-	-	669	624	113
80-160				606	566	-	90	627	588	-	93	200	20	-	656	611	103
80-200				606	566	-	105	627	588	-	108	200	20	-	656	611	118
80-250				619	579	-	122	640	601	-	125	200	-	25	669	624	135
100-200				606	566	-	122	627	588	-	125	200	-	-	656	611	135

DIMENSIONI FLANGE
Flanges dimensions

DN _A -DN _M	D	K	P	N° fori holes
25	115	85	14	4
32	140	100	18	4
40	150	110	18	4
50	165	125	18	4
65	185	145	18	4
80	200	160	18	8
100	220	180	18	8
125	250	210	18	8

FLANGE:

Dimensioni secondo UNI 2223 - 2229 PN16.

FLANGES:

Dimensions to UNI 2223 - 2229 NP16 standards

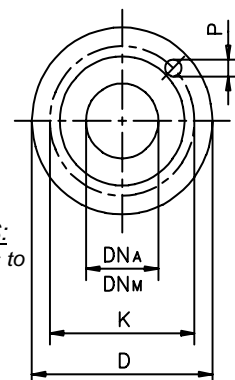

(1) Dimensioni in funzione della marca del motore elettrico installato / Not binding dimensions according to installed motor supplier

(h₃) (h₄) Spessori per allineamento motore - pompa esclusi dalla fornitura / Spacers for motor - pump alignment are not supplied by pompetravaini

RIF. - Ref.: F.P./C.T.

SOSTITUISCE - Replaces: 3900.100.201.01.B

DATA - Date: SETTEMBRE 2004 - September 2004

N°.: 3900.100.201.02.B



Москва, ул. Юности, д.5, стр. 4
Тел. (495) 988-78-29 Мегатехника.Москва
Единый телефон сервисной службы 8(800)100-77-83

Санкт-Петербург, ул. Софийская, д.17, оф. 311
Тел. (812) 331-70-11 Мегатехника.РФ
Единый телефон сервисной службы 8(800)100-77-83