

Versione **ACCOPIATA (BASE - GIUNTO SPAZIATORE)**  
**COUPLED construction (BASEPLATE - SPACER COUPLING)**

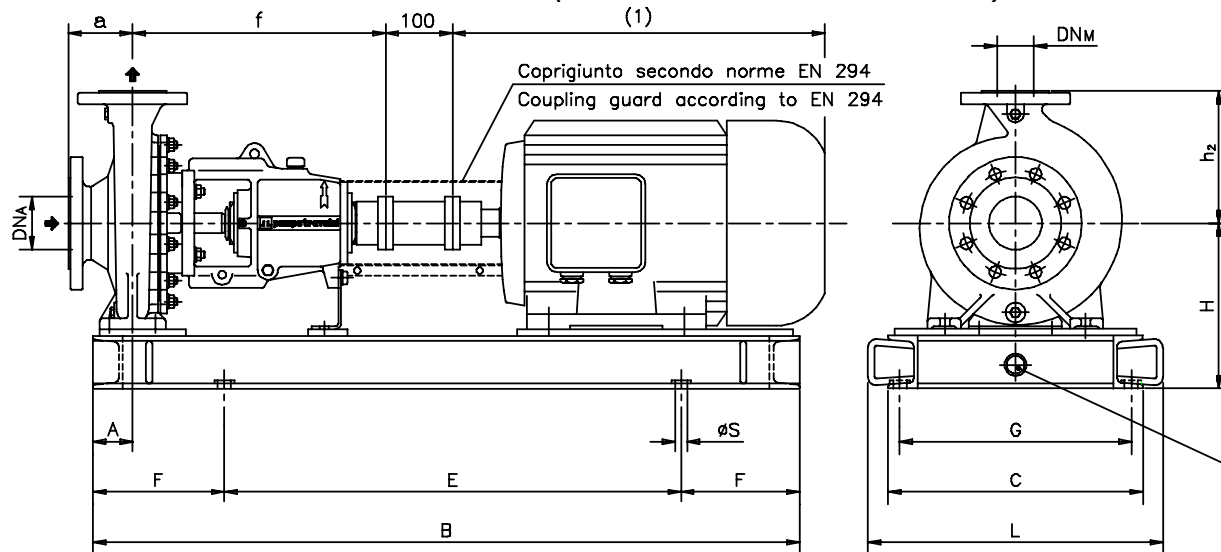

Ø1/2" Gas drenaggio basamento (optional)  
 Ø1/2" Gas baseplate drain (optional)

Pompa tipo Pump type	DIMENSIONI Dimensions						MOTORE ELETTRICO <i>Electric Motor</i>																		
							80M		90S/90L		100L		112M		132S/132M		160M/160L								
	DN <sub>A</sub>	DN <sub>M</sub>	a	f	h <sub>2</sub>	A	N°	H	Peso Weight	N°	H	Peso Weight	N°	H	Peso Weight	N°	H	Peso Weight	N°	H	Peso Weight	N°	H	Peso Weight	
25-125	40	25	80	385	140	60	C01	202	67	C01	202	66,5	C03	202	80,5	C03	202	77	C03	222	82				
25-160	40	25	80	385	160	60	C01	222	71	C01	222	70,5	C03	222	84	C03	222	83,5	C03	222	83				
25-200	40	25	80	385	180	60	C01	250	75	C03	250	87,5	C03	250	88	C03	250	87,5	C03	250	87				
32-125	50	32	80	385	140	60	C01	202	70	C01	202	69,5	C03	202	81,5	C03	202	80	C03	222	85				
32-160	50	32	80	385	160	60	C01	222	73	C01	222	72,5	C03	222	86	C03	222	85,5	C03	222	85				
32-200	50	32	80	385	180	60	C01	250	77,5	C01	250	79	C03	250	91	C03	250	92	C03	250	95	C05	250	97	
32-250	50	32	100	500	225	75				C03	270	129	C03	270	129	C03	270	130	C05	270	135	C05	270	134	
40-125	65	40	80	385	140	60	C01	202	71	C01	202	70,5	C03	202	82,5	C03	202	81	C03	222	86	C05	250	92	
40-160	65	40	80	385	160	60	C01	222	75	C01	222	74,5	C03	222	88	C03	222	87,5	C03	222	89	C05	250	98	
40-200	65	40	100	385	180	60	C01	250	80	C01	250	81	C03	250	94	C03	250	94	C03	250	97	C05	250	99	
40-250	65	40	100	500	225	75				C03	270	131	C03	270	131	C03	270	132	C05	270	138	C11	310	175	
40-315	65	40	125	500	250	75				C03	290	135	C03	290	135	C03	290	134	C05	290	142	C11	330	179	
50-125	80	50	100	385	160	60	C01	222	75	C01	222	74,5	C03	222	88	C03	222	87,5	C03	222	89	C05	250	98	
50-160	80	50	100	385	180	60	C01	250	79	C01	250	80	C03	250	93	C03	250	93	C03	250	96	C05	250	98	
50-200	80	50	100	385	200	60	C01	250	81	C01	250	82	C03	250	95	C03	250	95	C03	250	98	C05	250	100	
50-250	80	50	125	500	225	75				C03	270	133	C03	270	135	C03	270	135	C05	270	141	C11	310	180	
50-315	80	50	125	500	280	75				C03	315	134	C03	315	133	C03	315	133	C05	315	138	C11	355	179	
65-125	100	65	100	385	180	75	C01	250	105	C03	250	117	C03	250	117	C03	250	114	C03	250	129	C05	250	135	
65-160	100	65	100	500	200	75				C03	250	122	C03	250	123	C03	250	123	C05	250	130	C11	290	161	
65-200	100	65	100	500	225	75				C03	270	137	C03	270	138	C03	270	138	C05	270	144	C11	310	183	
65-250	100	65	125	500	250	90				C05	290	141	C05	290	141	C05	290	141	C05	290	142	C11	330	182	
80-160	125	80	125	500	225	75				C03	270	131	C03	270	127	C03	270	127	C05	270	130	C11	310	174	
80-200	125	80	125	500	250	75				C03	270	143	C03	270	142	C03	270	142	C05	270	148	C11	310	189	
80-250	125	80	125	500	280	90												C05	315	165	C11	355	203		
100-200	125	100	125	500	280	90				C05	290	167	C05	290	166	C05	290	166	C05	290	166	C11	330	204	

DISEGNO SCHEMATICO. DIMENSIONI IN MM CON TOLLERANZE SECONDO EN 735-1995. PESI INDICATIVI IN KG, RIFERITI A POMPE IN ESECUZIONE "GS" GHISA SFEROIDALE ESCLUSO MOTORE, NON IMPEGNATIVI. / Schematic drawing. Dimensions in mm with tolerances according to EN 735-1995 standards. Weights in Kgs, referred to pump in ductile iron "GS" construction without motor, not certified.

(1) DIMENSIONI IN FUNZIONE DELLA MARCA DEL MOTORE ELETTRICO INSTALLATO / Not certified dimensions according to installed motor manufacture

RIF. - Ref.: E.Z./C.T.

SOSTITUISCE - Replaces: 3700.1L5.2001.06.01

DATA - Date: NOVEMBRE 2011 - November 2011

N°.: 3700.1L5.2001.07.01

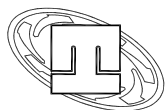

**Versione ACCOPPIATA (BASE - GIUNTO SPAZIATORE)**  
**COUPLED construction (BASEPLATE - SPACER COUPLING)**

**BASAMENTI**  
*Base plates*

N°	B	C	E	F	L	G	øS	N°fori holes
C01	800	320	500	150	380	280	18	4
C03	1000	385	600	200	445	345	18	4
C05	1200	420	800	200	480	380	18	4
C11	1350	500	950	200	570	452	18	4
C13	1650	640	1050	300	710	592	18	4

**DIMENSIONI FLANGE**  
*Flanges dimensions*

DN <sub>A</sub> -DN <sub>M</sub>	D	K	P	N°fori holes
25	115	85	14	4
32	140	100	18	4
40	150	110	18	4
50	165	125	18	4
65	185	145	18	4
80	200	160	18	8
100	220	180	18	8
125	250	210	18	8

**FLANGE:**

Dimensioni secondo  
 UNI 2223-2229 PN16

**FLANGES:**

Dimensions to  
 UNI 2223-2229 NP16  
 standards

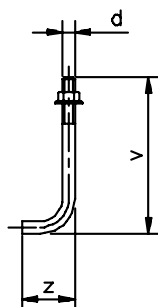

**BULLONI DI FONDAZIONE**  
 (OPTIONAL)  
*Foundation bolts*

d	v	z
M14	280	50
M16	350	60
M20	400	80

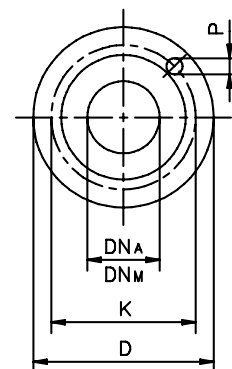

Pompa tipo Pump type	MOTORE ELETTRICO <i>Electric Motor</i>														
	180M/180L			200L			225S/225M			250M			280S/280M		
	N°	H	Peso Weight	N°	H	Peso Weight	N°	H	Peso Weight	N°	H	Peso Weight	N°	H	Peso Weight
25-125															
25-160															
25-200															
32-125															
32-160															
32-200															
32-250	C05	270	134												
40-125															
40-160															
40-200	C05	270	99												
40-250	C11	310	172												
40-315	C11	330	177	C11	330	207									
50-125															
50-160	C05	270	98												
50-200	C05	270	100	C11	330	139									
50-250	C11	310	180	C11	330	170	C13	358	172	C13	383	173	C13	413	177
50-315	C11	355	179	C11	355	208	C13	358	204	C13	383	208	C13	413	210
65-125															
65-160	C11	310	168	C11	330	230									
65-200	C11	310	180	C11	330	205	C13	358	205	C13	383	205	C13	413	206
65-250	C11	330	179	C11	330	209	C13	358	212	C13	383	213	C13	413	216
80-160	C11	310	171	C11	330	205	C13	358	207	C13	383	205			
80-200	C11	310	188	C11	330	220	C13	358	222	C13	383	220	C13	413	222
80-250	C11	355	203	C11	355	235	C13	358	233	C13	383	235	C13	413	237
100-200	C11	330	204	C11	330	236	C13	358	234	C13	383	236	C13	413	238

**MOTORI ELETTRICI**  
*Electric Motors*

Grandezza Frame size	Giri/min RPM	Giri/min RPM
	2900	1450
IEC	Kw	Kw
80M	0,75 1,1	0,55 0,75
90S	1,5	1,1
90L	2,2	1,5
100L	3	2,2 3
112M	4	4
132S	5,5-7,5	5,5
132M		7,5
160M	11-15	11
160L	18,5	15
180M	22	18,5
180L		22
200L	30-37	30
225S		37
225M	45	45
250M	55	55
280S	75	75
280M	90	90

DISEGNO SCHEMATICO. DIMENSIONI IN MM CON TOLLERANZE SECONDO EN 735-1995. PESI INDICATI IN KG, RIFERITI A POMPE IN ESECUZIONE "GS" GHISA SFEROIDALE ESCLUSO MOTORE, NON IMPEGNATIVI. / Schematic drawing. Dimensions in mm with tolerances according to EN 735-1995 standards. Weights in Kgs, referred to pump in ductile iron "GS" construction without motor, not certified.

(1) DIMENSIONI IN FUNZIONE DELLA MARCA DEL MOTORE ELETTRICO INSTALLATO / Not certified dimensions according to installed motor manufacture

RIF. - Ref.: E.Z./C.T.

SOSTITUISCE - Replaces: 3700.1L5.2001.06.02

DATA - Date: NOVEMBRE 2011 - November 2011

N°.: 3700.1L5.2001.07.02