

Versione **ACCOPPIATA (BASE - GIUNTO)**  
**COUPLED construction (BASEPLATE - COUPLING)**

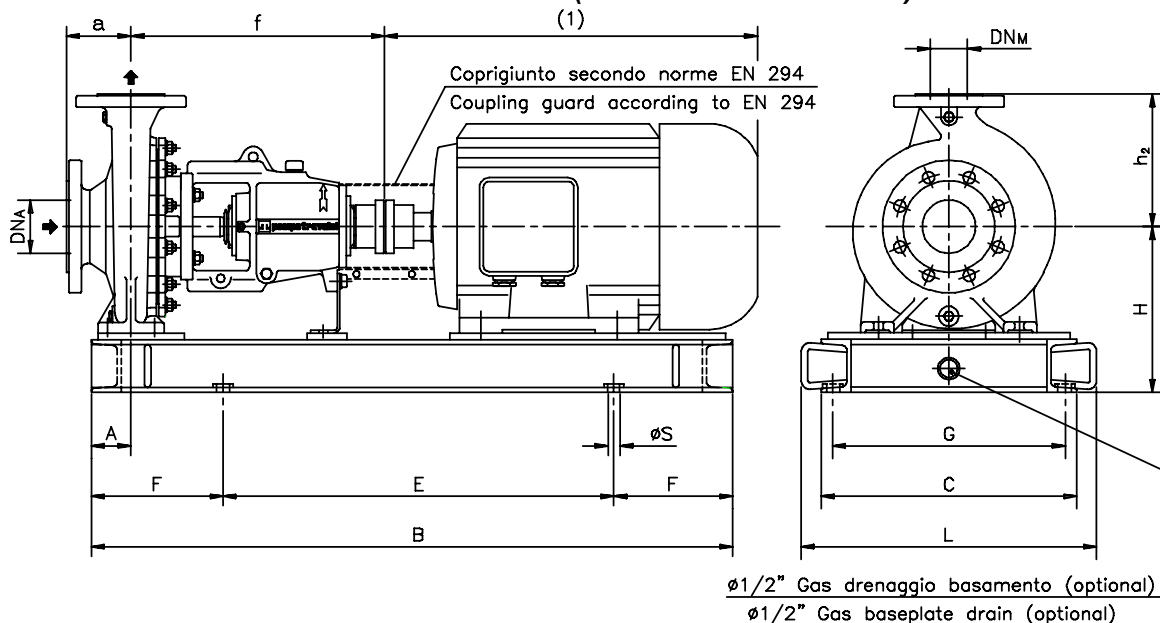

Pompa tipo Pump type	DIMENSIONI Dimensions						MOTORE ELETTRICO <i>Electric Motor</i>																	
							80M			90S/90L			100L			112M			132S/132M			160M/160L		
	DN <sub>A</sub>	DN <sub>M</sub>	a	f	h <sub>2</sub>	A	N°	H	Peso Weight	N°	H	Peso Weight	N°	H	Peso Weight	N°	H	Peso Weight	N°	H	Peso Weight	N°	H	Peso Weight
25-125	40	25	80	385	140	60	C01	202	65	C01	202	64,5	C01	202	63,5	C01	202	62	C03	222	80			
25-160	40	25	80	385	160	60	C01	222	69	C01	222	68,5	C01	222	69	C01	222	68,5	C03	222	81			
25-200	40	25	80	385	180	60	C01	250	73	C01	250	72,5	C01	250	73	C01	250	70	C03	250	85			
32-125	50	32	80	385	140	60	C01	202	68	C01	202	67,5	C01	202	66,5	C01	202	65	C03	222	83			
32-160	50	32	80	385	160	60	C01	222	71	C01	222	70,5	C01	222	71	C01	222	70,5	C03	222	83			
32-200	50	32	80	385	180	60	C01	250	75,5	C01	250	77	C01	250	76	C01	250	77	C03	250	93	C03	250	89
32-250	50	32	100	500	225	75				C03	270	127	C03	270	127	C03	270	128	C03	270	128	C05	270	132
40-125	65	40	80	385	140	60	C01	202	69	C01	202	68,5	C01	202	67,5	C01	202	66	C03	222	84	C03	250	84
40-160	65	40	80	385	160	60	C01	222	73	C01	222	72,5	C01	222	73	C01	222	72,5	C03	222	87	C03	250	90
40-200	65	40	100	385	180	60	C01	250	78	C01	250	79	C01	250	79	C01	250	79	C03	250	95	C03	250	91
40-250	65	40	100	500	225	75				C03	270	129	C03	270	129	C03	270	130	C03	270	130	C05	270	134
40-315	65	40	125	500	250	75				C03	290	133	C03	290	133	C03	290	134	C03	290	134	C05	290	138
50-125	80	50	100	385	160	60	C01	222	73	C01	222	72,5	C01	222	73	C01	222	72,5	C03	222	87	C03	250	90
50-160	80	50	100	385	180	60	C01	250	77	C01	250	78	C01	250	78	C01	250	78	C03	250	94	C03	250	90
50-200	80	50	100	385	200	60	C01	250	79	C01	250	80	C01	250	80	C01	250	80	C03	250	96	C03	250	92
50-250	80	50	125	500	225	75							C03	270	131	C03	270	133	C03	270	133	C05	270	139
50-315	80	50	125	500	280	75							C03	315	132	C03	315	131	C03	315	130	C05	315	138
65-125	100	65	100	385	180	75	C03	250	117	C03	250	117	C03	250	117	C03	250	118	C03	250	115	C03	250	115
65-160	100	65	100	500	200	75				C03	250	120	C03	250	121	C03	250	121	C03	250	122	C05	250	121
65-200	100	65	100	500	225	75							C03	270	135	C03	270	136	C03	270	136	C05	270	142
65-250	100	65	125	500	250	90							C05	290	139	C05	290	139	C05	290	140	C05	290	141
80-160	125	80	125	500	225	75							C03	270	129	C03	270	125	C03	270	122	C05	270	133
80-200	125	80	125	500	250	75							C03	270	141	C03	270	140	C03	270	140	C05	270	148
80-250	125	80	125	500	280	90												C05	315	163	C05	315	162	
100-200	125	100	125	500	280	90							C05	290	165	C05	290	164	C05	290	164	C05	290	163

DISEGNO SCHEMATICO. DIMENSIONI IN MM CON TOLLERANZE SECONDO EN 735-1995. PESI INDICATI IN KG, RIFERITI A POMPE IN ESECUZIONE "GS" GHISA SFEROIDALE ESCLUSO MOTORE, NON IMPEGNATIVI.

Schematic drawing. Dimensions in mm with tolerances to EN 735-1995 standards. Weights in Kgs, referred to pump in ductile iron "GS" construction without motor, not certified.

(1) DIMENSIONI IN FUNZIONE DELLA MARCA DEL MOTORE ELETTRICO INSTALLATO / Not certified dimensions according to installed motor manufacture

RIF. - Ref.: E.Z./C.T.

SOSTITUISCE - Replaces: 3700.1L3.2001.07.01

DATA - Date: NOVEMBRE 2011 - November 2011

N°.: 3700.1L3.2001.08.01

**DIMENSIONI D'INGOMBRO / Overall dimensions.**  
**POMPE CENTRIFUGHE MONOSTADIO**  
*Monostage centrifugal pumps*  
**SERIE / Series**  
**TCH & TCA gr. 1-2 pag.2/2**

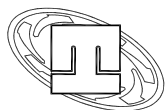

**pompetravaini S.p.A.**  
**CASTANO PRIMO (MILANO)**

Versione **ACCOPIATA (BASE - GIUNTO)**  
**COUPLED construction (BASEPLATE - COUPLING)**

**BASAMENTI**  
*Base plates*

N°	B	C	E	F	L	G	øS	N°fori holes
C01	800	320	500	150	380	280	18	4
C03	1000	385	600	200	445	345	18	4
C05	1200	420	800	200	480	380	18	4
C11	1350	500	950	200	570	452	18	4
C13	1650	640	1050	300	710	592	18	4

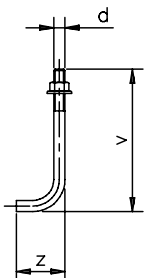

**BULLONI DI FONDAZIONE (OPTIONAL)**  
*Foundation bolts*

d	v	z
M14	280	50
M16	350	60
M20	400	80

**DIMENSIONI FLANGE**  
*Flanges dimensions*

DN <sub>A</sub> -DN <sub>M</sub>	D	K	P	N°fori holes
25	115	85	14	4
32	140	100	18	4
40	150	110	18	4
50	165	125	18	4
65	185	145	18	4
80	200	160	18	8
100	220	180	18	8
125	250	210	18	8

**FLANGE:**

Dimensioni secondo  
 UNI 2223-2229 PN16

**FLANGES:**

Dimensions to UNI 2223-2229  
 NP16 standards

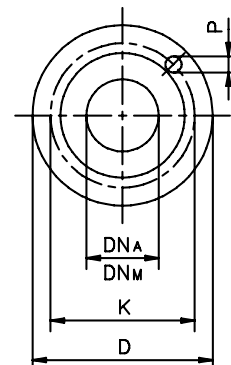

Pompa tipo Pump type	MOTORE ELETTRICO <i>Electric Motor</i>														
	180M/180L			200L			225S/225M			250M			280S/280M		
	N°	H	Peso Weight	N°	H	Peso Weight	N°	H	Peso Weight	N°	H	Peso Weight	N°	H	Peso Weight
25-125															
25-160															
25-200															
32-125															
32-160															
32-200															
32-250	C05	270	130												
40-125															
40-160															
40-200	C05	270	97												
40-250	C05	270	131	C11	330	172									
40-315	C05	290	136	C11	330	176									
50-125															
50-160	C05	270	96												
50-200	C05	270	98	C11	330	137									
50-250	C05	270	136	C11	330	138	C11	355	140	C13	383	171	C13	413	175
50-315	C05	315	138	C11	355	176	C11	355	172	C13	383	206	C13	413	208
65-125															
65-160	C05	270	127	C11	330	198									
65-200	C05	270	139	C11	330	173	C11	355	173	C13	383	203	C13	413	204
65-250	C05	290	138	C11	330	177	C11	355	180	C13	383	211	C13	413	214
80-160	C05	270	130	C11	330	173	C11	355	175	C13	383	203			
80-200	C05	270	147	C11	330	188	C11	355	190	C13	383	218	C13	413	220
80-250	C05	315	162	C11	355	203	C11	355	201	C13	383	233	C13	413	235
100-200	C05	290	163	C11	330	204	C11	355	202	C13	383	234	C13	413	236

**MOTORI ELETTRICI**  
*Electric Motors*

Grandezza Frame size	Giri/min RPM	Giri/min RPM
	2900	1450
IEC	Kw	Kw
80M	0,75	0,55
	1,1	0,75
90S	1,5	1,1
90L	2,2	1,5
		2,2
		3
100L	3	
112M	4	4
132S		5,5
132M	5,5-7,5	7,5
160M	11-15	11
160L	18,5	15
180M	22	18,5
180L		22
200L	30-37	30
225S		37
225M	45	45
250M	55	55
280S	75	75
280M	90	90

DISEGNO SCHEMATICO. DIMENSIONI IN MM CON TOLLERANZE SECONDO EN 735-1995. PESI INDICATIVI IN KG, RIFERITI A POMPE IN ESECUZIONE "GS" GHISA SFEROIDALE ESCLUSO MOTORE, NON IMPEGNATIVI.

Schematic drawing. Dimensions in mm with tolerances according to EN 735-1995 standards. Weights in Kgs, referred to pump in ductile iron "GS" construction without motor, not certified.

(1) DIMENSIONI IN FUNZIONE DELLA MARCA DEL MOTORE ELETTRICO INSTALLATO / Not certified dimensions according to installed motor manufacture

RIF. - Ref.: E.Z./C.T.

SOSTITUISCE - Replaces: 3700.1L3.2001.07.02

DATA - Date: NOVEMBRE 2011 - November 2011

N°.: 3700.1L3.2001.08.02



Москва, ул. Юности, д.5, стр. 4  
 Тел. (495) 988-78-29 Мегатехника.Москва  
 Единый телефон сервисной службы 8(800)100-77-83

Санкт-Петербург, ул. Софийская, д.17, оф. 311  
 Тел. (812) 331-70-11 Мегатехника.РФ  
 Единый телефон сервисной службы 8(800)100-77-83