

DIMENSIONI D'INGOMBRO
Overall dimensions
POMPE CENTRIFUGHE MONOSTADIO
Monostage centrifugal pumps
SERIE
Series **TCH & TCA gr. 1-2** pag.1/2

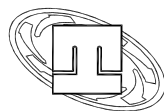

pompetravaini S.p.A.
CASTANO PRIMO (MILANO)

Versione ad **ASSE NUDO**
Unificate secondo ISO 2858

BARESHAF construction
According to ISO 2858 standards

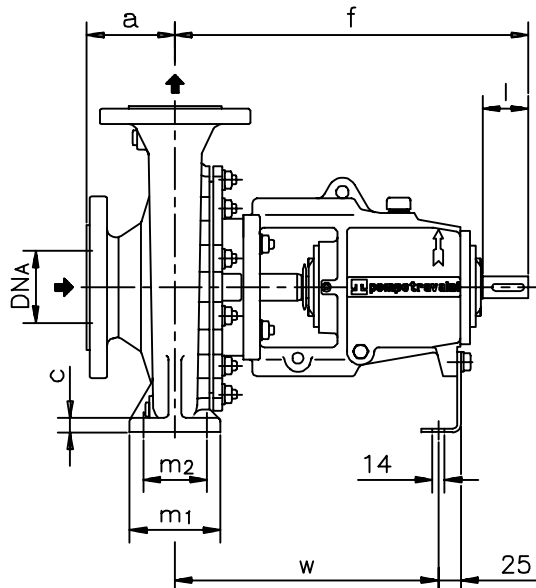
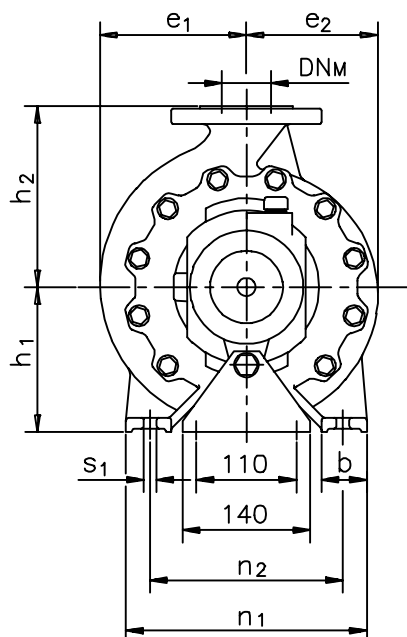

Pompa tipo Pump type	Versione ad ASSE NUDO BARESHAF construction																				Peso Weight
	DN _A	DN _M	a	f	h ₁	h ₂	b	c	m ₁	m ₂	n ₁	n ₂	s ₁	w	d ₁	l	t	u	e ₁	e ₂	
25-125	40	25	80	385	112	140	50	15	100	70	190	140	14	285	24	50	27	8	95	90	32
25-160	40	25	80	385	132	160	50	16	100	70	240	190	14	285	24	50	27	8	110	108	36
25-200	40	25	80	385	160	180	50	16	100	70	240	190	14	285	24	50	27	8	133	128	40
32-125	50	32	80	385	112	140	50	15	100	70	190	140	14	285	24	50	27	8	105	91	35
32-160	50	32	80	385	132	160	50	16	100	70	240	190	14	285	24	50	27	8	125	110	38
32-200	50	32	80	385	160	180	50	16	100	70	240	190	14	285	24	50	27	8	140	130	44
32-250	50	32	100	500	180	225	65	18	125	95	320	250	14	370	32	80	35	10	166	162	80
40-125	65	40	80	385	112	140	50	15	100	70	210	160	14	285	24	50	27	8	115	100	36
40-160	65	40	80	385	132	160	50	16	100	70	240	190	14	285	24	50	27	8	130	115	40
40-200	65	40	100	385	160	180	50	16	100	70	265	212	14	285	24	50	27	8	146	135	46
40-250	65	40	100	500	180	225	65	18	125	95	320	250	14	370	32	80	35	10	176	163	82
40-315	65	40	125	500	200	250	65	18	125	95	345	280	14	370	32	80	35	10	205	200	86
50-125	80	50	100	385	132	160	50	16	100	70	240	190	14	285	24	50	27	8	130	110	40
50-160	80	50	100	385	160	180	50	16	100	70	265	212	14	285	24	50	27	8	147	125	45
50-200	80	50	100	385	160	200	50	16	100	70	265	212	14	285	24	50	27	8	161	146	47
50-250	80	50	125	500	180	225	65	18	125	95	320	250	14	370	32	80	35	10	183	169	85
50-315	80	50	125	500	225	280	65	18	125	95	345	280	14	370	32	80	35	10	210	197	82
65-125	100	65	100	385	160	180	65	16	125	95	280	212	14	285	24	50	27	8	145	117	70
65-160	100	65	100	500	160	200	65	16	125	95	280	212	14	370	32	80	35	10	160	130	73
65-200	100	65	100	500	180	225	65	18	125	95	320	250	14	370	32	80	35	10	174	152	80
65-250	100	65	125	500	200	250	80	20	160	120	360	280	18	370	32	80	35	10	195	175	85
65-400	100	65	125	500	250	300	100	22	160	120	500	400	22	370	32	80	35	10	250	235	130
80-160	125	80	125	500	180	225	65	16	125	95	320	250	14	370	32	80	35	10	186	142	78
80-200	125	80	125	500	180	250	65	18	125	95	345	280	14	370	32	80	35	10	188	158	93
80-250	125	80	125	500	225	280	80	20	160	120	400	315	18	370	32	80	35	10	225	185	108
100-200	125	100	125	500	200	280	80	20	160	120	360	280	18	370	32	80	35	10	211	170	99

Disegno schematico. Dimensioni in mm con tolleranze secondo EN 735-1995. Pesi indicativi in Kg, riferiti a pompe in esecuzione "GS" ghisa sferoidale escluso motore, non impegnativi.
Schematic drawing. Dimensions in mm with tolerances to EN 735-1995 standards. Weights in Kgs, referred to pump in ductile iron "GS" construction without motor, not certified.

RIF. - Ref.: F.P./C.T.

SOSTITUISCE - Replaces: 3700.100.201.02.A

DATA - Date: NOVEMBRE 2006 - November 2006

N°.: 3700.100.201.03.A



Москва, ул. Юности, д.5, стр. 4
Тел. (495) 988-78-29 Мегатехника.Москва
Единый телефон сервисной службы 8(800)100-77-83

Санкт-Петербург, ул. Софийская, д.17, оф. 311
Тел. (812) 331-70-11 Мегатехника.РФ
Единый телефон сервисной службы 8(800)100-77-83