

DIMENSIONE D'INGOMBRO / Overall dimensions
POMPE CENTRIFUGHE AUTOADESCANTI

Self-priming centrifugal pumps

SERIE / Series

TBH 290-300-310/1

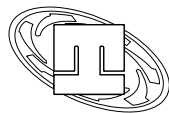

pompetravaini S.p.A.

CASTANO PRIMO (MILANO)

Versione **ACCOPIATA (BASE-GIUNTO)** -
COUPLED construction (BASEPLATE-COUPLING)

Esecuzione /R
Construction /R

Esecuzione /C Construction /C

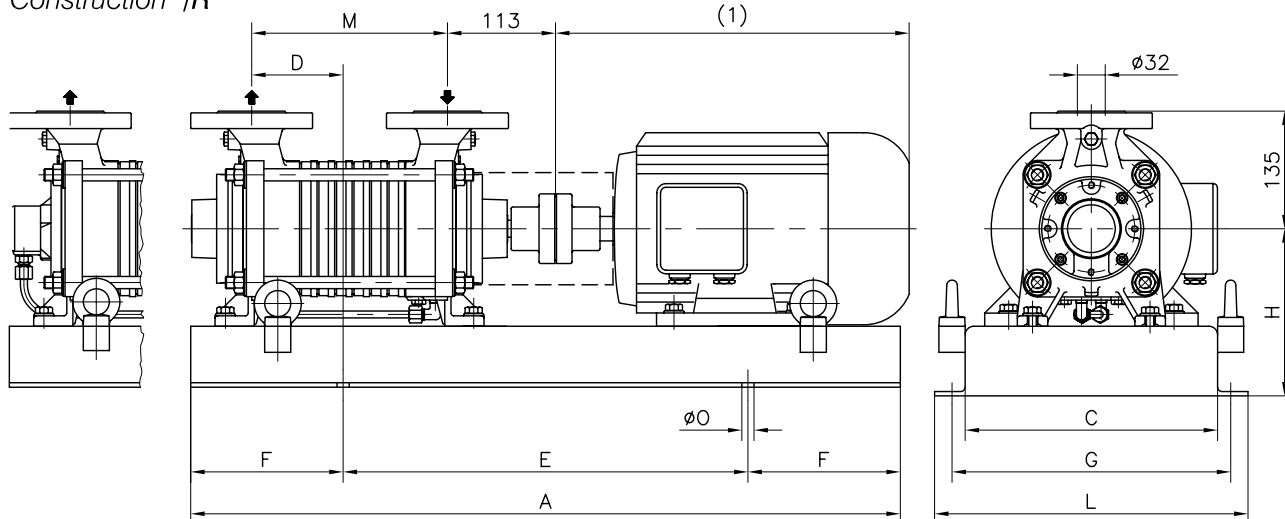

FLANGE: Dimensioni secondo UNI 2223-2229 PN40

FLANGES: Dimensions to UNI 2223-2229 NP40 standards

POMPA TIPO Pump type	M	MOTORE ELETTRICO Electric motor																			
		80M			90S / 90L			100L			112M			132S / 132M							
		N°	D	H	Peso Weight	N°	D	H	Peso Weight	N°	D	H	Peso Weight	N°	D	H	Peso Weight				
TBH 291 - 301 - 311	144	902	50	162	40	902	75	162	42	902	78	162	40								
TBH 292 - 302 - 312	184	902	70	162	43	901	80	172	49	901	100	172	47	901	100	172	45				
TBH 293 - 303 - 313	224					901	100	172	52	901	120	172	50	901	105	172	48	900	50	197	61
TBH 294 - 304 - 314	264					901	120	172	55	901	133	172	53	901	125	172	51	900	80	197	64
TBH 295 - 305 - 315	304					901	133	172	58	900	60	177	65	900	45	177	63	900	100	197	67
TBH 296 - 306 - 316	344									900	80	177	68	900	65	177	66	900	120	197	70
TBH 297 - 307 - 317	384									900	100	177	71	900	85	177	69	900	135	197	74
TBH 298 - 308 - 318	424													900	90	177	73	903	60	222	98

POMPA TIPO Pump type	M	160M / 160L			
		N°	D	H	Peso Weight
TBH 291 - 301 - 311	144				
TBH 292 - 302 - 312	184				
TBH 293 - 303 - 313	224				
TBH 294 - 304 - 314	264	903	50	250	94
TBH 295 - 305 - 315	304	903	70	250	97
TBH 296 - 306 - 316	344	903	90	250	101
TBH 297 - 307 - 317	384	903	120	250	104
TBH 298 - 308 - 318	424	903	130	250	107

MOTORI ELETTRICI
Electric Motors

Grandezza Frame size IEC	Giri/min. RPM
	Kw
80M	0,55
	0,75
90S	1,1
90L	1,5
100L	2,2
	3
112M	4
132S	5,5
132M	7,5
160M	11
160L	15

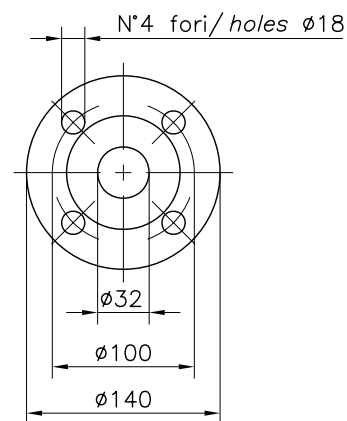

BASAMENTI Base plates									
N°	A	C	E	F	L	G	S	Ø	N° fori holes
900	960	310	600	180	370	340	5	14	4
901	770	290	420	175	350	320	5	14	4
902	610	210	370	120	270	240	5	14	4
903	1170	350	770	200	410	380	6	14	4

Disegno schematico. Dimensioni in mm con tolleranze secondo EN 735-1995. Pesì indicativi in Kg, riferiti a pompe in ghisa escluso motore, non impegnativi.
Schematic drawing. Dimensions in mm with tolerances to EN 735-1995 standards. Weights in Kgs, referred to pumps in cast iron without motor, not certified.

(1) Dimensioni in funzione della marca del motore installato. (1) Not certified dimensions according to installed motor manufacture.

RIF. - Ref.: E.Z./C.T.	DOCUMENTO N. - Document no.: 1032-33-34.1L3.2001.03.01	ITEM n° D00096R
DATA - Date: 09-2009	SOSTITUISCE DOC. - Replaces Doc. (ITEM): 1032-4.1L3.201.02 (-)	



Москва, ул. Юности, д.5, стр. 4
Тел. 8(800) 100-78-28 Мегатехника.Москва
Единый телефон сервисной службы 8(800)100-77-83

Санкт-Петербург, ул. Софийская, д.17, оф. 311
Тел. (812) 331-70-11 Мегатехника.РФ