

Versione **ACCOPIATA (BASE-GIUNTO)**
COUPLED construction (BASEPLATE-COUPLING)

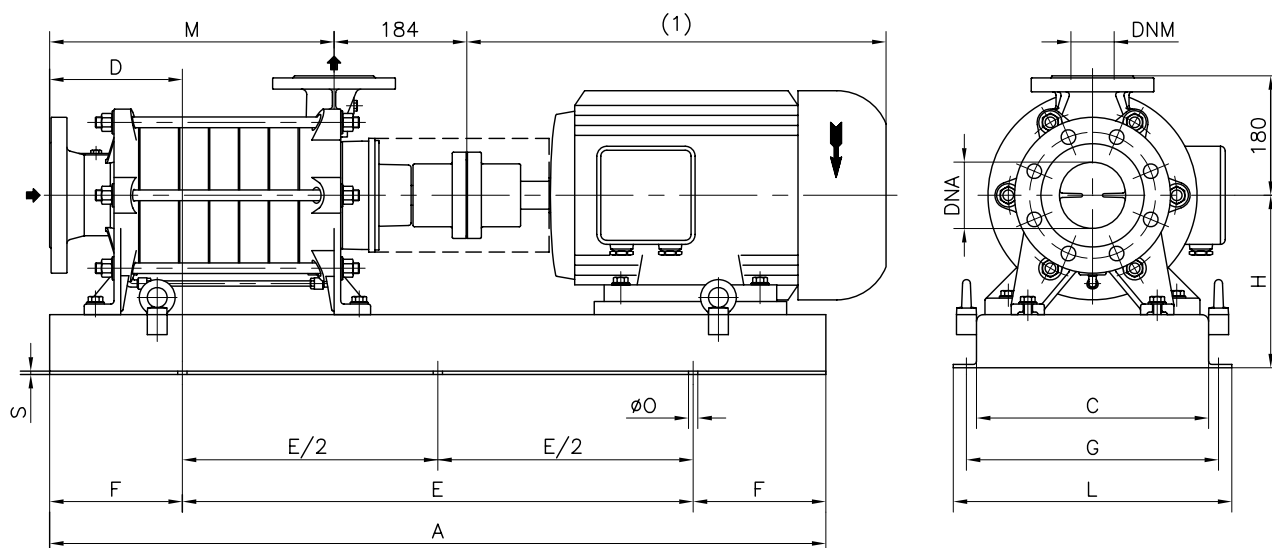

FLANGE: Dimensioni secondo UNI 2223-2229 PN40

FLANGES: Dimensions to UNI 2223-2229 NP40 standards

POMPA TIPO Pump type	DIMENSIONI Dimensions			MOTORE ELETTRICO Electric motor																				
	DNA	DNM	M	132S / 132M			160M / 160L			180M / 180L			200L			225S / 225M								
	N°	D	H	Peso Weight	N°	D	H	Peso Weight	N°	D	H	Peso Weight	N°	D	H	Peso Weight	N°	D	H	Peso Weight				
TBA 651	100	65	338		900	175	245	113	903	115	270	127												
TBA 652	100	65	428		900	220	245	128	903	200	270	142	907	165	280	150								
TBA 653	100	65	518		903	180	270	162	906	225	270	167	041	210	330	180	041	215	330	184	034	110	355	190
TBA 654	100	65	608		903	227	270	177	906	225	270	182	041	245	330	195	041	265	330	199	034	200	355	220
TBA 655	100	65	698		906	182	280	202	906	185	280	197	034	270	310	225	034	270	330	230	034	270	355	235
TBA 656	100	65	788										034	310	310	240	034	310	330	245	034	310	355	250
TBA 657	100	65	878										034	352	310	255	034	352	330	260	034	352	355	265
TBA 658	100	65	968										034	352	330	275	034	352	330	275	034	352	355	280

POMPA TIPO Pump type	MOTORE ELETTRICO Electric motor							
	250M				280S / 280M			
	N°	D	H	Peso Weight	N°	D	H	Peso Weight
TBA 651								
TBA 652								
TBA 653								
TBA 654								
TBA 655								
TBA 656	039	100	385	287	039	100	415	285
TBA 657	039	200	385	287	039	270	415	300
TBA 658	039	287	385	287	039	287	415	315

DIMENSIONI FLANGE Flanges dimensions				
DNA - DNM	N	K	P	N° fori holes
65	185	145	18	8
100	235	190	22	8

**MOTORI ELETTRICI
Electric Motors**

Grandezza Frame size IEC	Giri/min. RPM 1450
	Kw
132S	5,5
132M	7,5
160M	11
160L	15
180M	18,5
180L	22
200L	30
225S	37
225M	45
250M	55
280S	75
280M	90

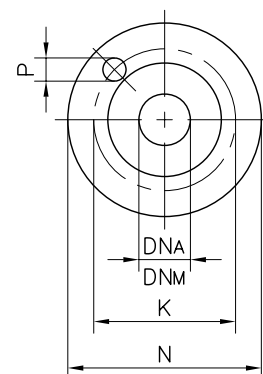

BASAMENTI Base plates									
N°	A	C	E	F	L	G	S	øO	N° fori holes
900	960	310	600	180	370	340	5	14	4
903	1170	350	770	200	410	380	6	14	4
906	1400	350	950	225	410	380	6	14	4
907	1200	420	900	150	510	470	6	18	4
034	1700	450	1100	300	590	540	7	18	4
039	2150	540	1600	275	680	630	7	18	6
041	1350	420	900	225	560	510	7	18	4

Disegno schematico. Dimensioni in mm con tolleranze secondo EN 735-1995. Pesì indicativi in Kg, riferiti a pompe in ghisa escluso motore, non impegnativi.
 Schematic drawing. Dimensions in mm with tolerances to EN 735-1995 standards. Weights in Kgs, referred to pumps in cast iron without motor, not certified.

(1) Dimensioni in funzione della marca del motore installato. (1) Not certified dimensions according to installed motor manufacture.