

# MT 12-T2C

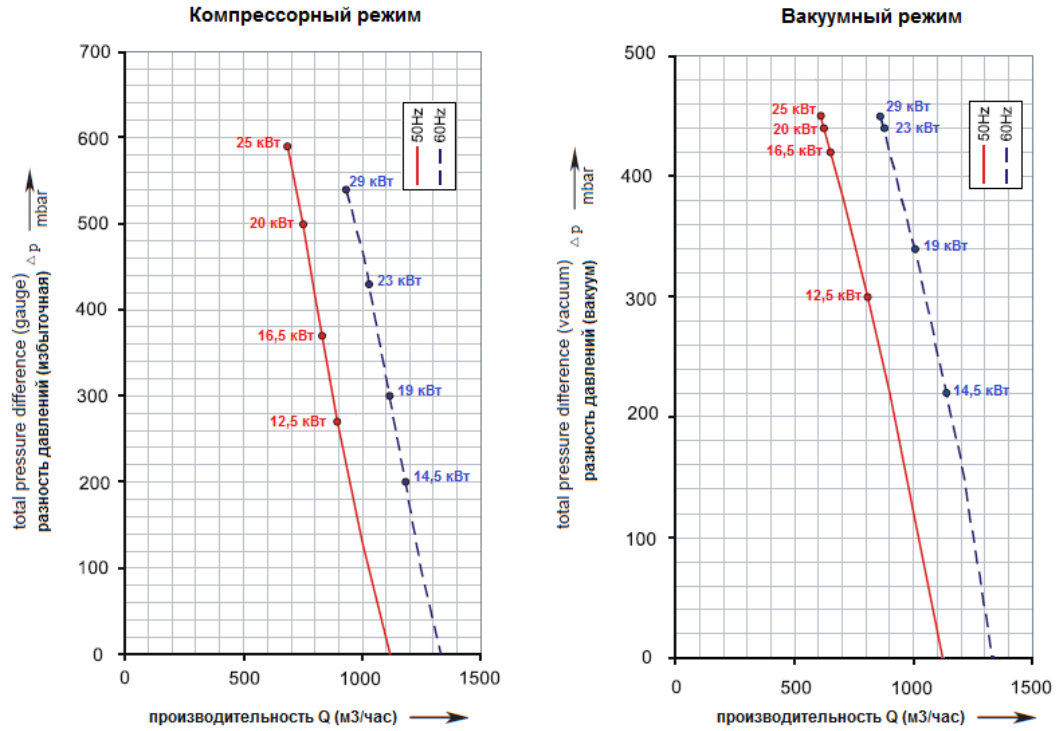

Type MT 12-T2C											
Curve No.	Order No.	Frequency	Rated power	Input voltage		Input current	Permissible total differential pressure		Sound pressure level *)	Weight ca.	
				Model	Частота		Мощность	Входное напряжение			Максимальная разность давлений
		Hz	kW	V		A	mbar	mbar	dB(A)	kg	
3~ 50/60 Hz IP55 insulation material class F (степень защиты IP55, нагревостойкость по классу F)											
12,5 кВт	MT 12-T2C-12,5	50	12.5	345D ... 415D	600Y...720Y	28.0D	16.2Y	270	-300	74	187
14,5 кВт	MT 12-T2C-14,5	60	14.5	380D ... 480D	660Y...720Y	29.0D	16.7Y	200	-220	84	187
16,5 кВт	MT 12-T2C-16,5	50	16.5	345D ... 415D	600Y...720Y	35.0D	20.0Y	370	-410	74	197
19 кВт	MT 12-T2C-19,0	60	19.0	380D ... 480D	660Y...720Y	36.5D	21.0Y	300	-340	84	197
20 кВт	MT 12-T2C-20,0	50	20.0	345D ... 415D	600Y...720Y	40.0D	23.0Y	500	-440	74	204
23 кВт	MT 12-T2C-23,0	60	23.0	380D ... 480D	660Y...720Y	42.0D	24.2Y	430	-440	84	204
25 кВт	MT 12-T2C-25,0	50	25.0	345D ... 415D	600Y...720Y	52.0D	30.0Y	590	-440	74	211
29 кВт	MT 12-T2C-29,0	60	29.0	380D ... 480D	660Y...720Y	52.0D	30.0Y	540	-440	84	211

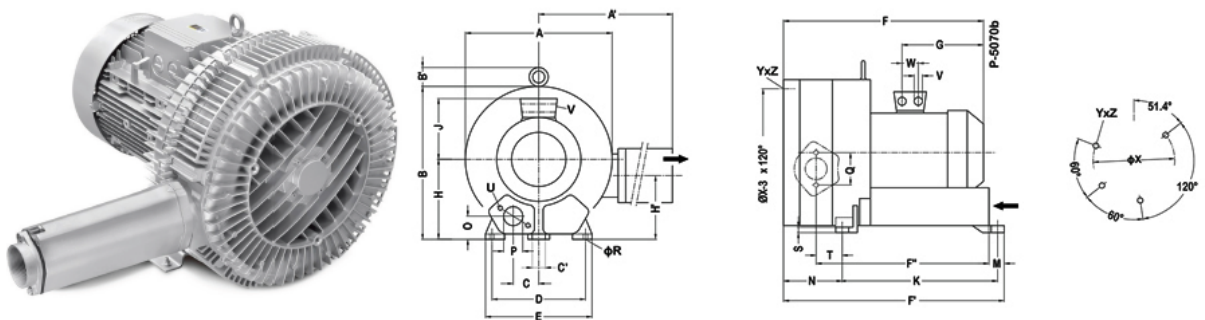

Размеры указаны в мм.									
Модель	эл. дв.	A	A'	B	B'	C	C'	D	E
MT 12-T2C	3~	614	780	607	16	103.5	15	360	415
		F	F'	F''	G	H	H'	J	
		812	786	634	345	300	234	197	
		K	M	N	O	P	Q	φR	S
		533	39	230	92	100	150	15	21
		T	U	V	W	φX	Y×Z	X-Holes	
117	M12×30	4×M40×1.5	54	490	M12×30	51°/120°/240°			